

BYOD | ASSEMBLY INSTRUCTION

CONTENTS

- [1] Top
- [1] Shelf
- [1] Stretcher
- [2] Leg
- [2] Pin



As you unpack, place the contents on a carpeted or padded area to protect them from damage. Improper unpacking can result in personal or property damage.

Serious or fatal crushing injuries can occur from furniture tip-over. To further reduce the risk of serious injury and death from tip-overs:

- Never stand on furniture
- Furniture intended for placement on floor

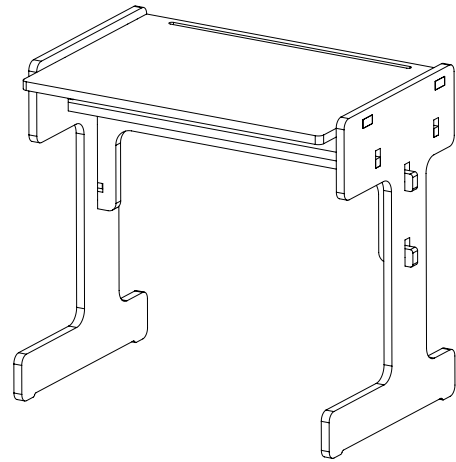

1 FITTING PARTS
Fit STRETCHER and SHELF together.

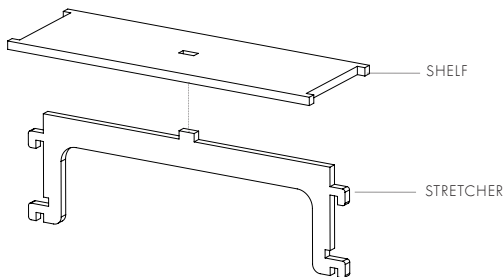

2 FITTING PARTS
Place a LEG on a padded floor. Fit the side of the TOP and parts from step 1 into cutouts on LEG. Fit the second LEG to the other side. Please note that all parts will be fitted loosely at the end of this step.

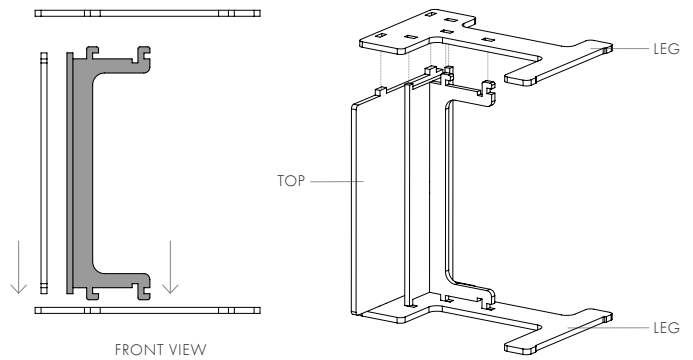

3 SECURING PARTS
Flip the desk to an upright position. Slide down parts from step 1 to lock all parts in place.

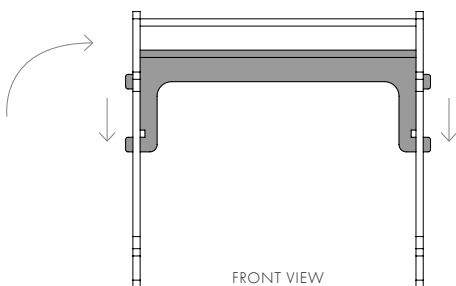

4 SECURING PARTS
Insert PINS on each side to secure all parts together. Make sure they are placed in a correct orientation as shown below.

